

Features

- Stainless steel front bezel display
- Flat front panel touch screen
- IP66/IP69K compliant front bezel
- VGA/DP/DVI/HDMI input
- OSD on the rear side
- System power LED light
- High brightness LCD for option
- Wide range DC 9~36V power input

Specifications

I/O Port	
VGA	1 x VGA
DVI	1 x DVI-D (share with HDMI)
DP	1 x DP
HDMI	1 x HDMI (share with DVI-D)
Audio	1 x Audio line-in phone jack
OSD Control	OSD at rear side
Membrane	On board controller, extendable key pad from connector
Power	1 x 3-pin terminal block for DC 9~36V power input
Others	1 x USB type B for touch control Optional I/O: 1 x Speaker

Display	Standard	High Brightness Optional
Display Type	10.1" TFT-LCD	10.1" TFT-LCD
Max. Resolution	1280 x 800	1280 x 800
Max. Color	16.7M	16.2M
Luminance (cd/m ²)	350/300	1000
View Angle	170(H) / 170(V)	170(H) / 170(V)
Contrast	800:1	1300:1
Backlight Lifetime	30,000 hrs	50,000 hrs

Touch Screen	
Type	Projected Capacitive Touch (for P model) Resistive Touch (for R model) Glass (for G model)
Interface	USB
Light Transmission(%)	Resistive Touch: over 80% Projected Capacitive Touch: over 90%

Power	
Power Input	DC 9~36V
Power Consumption	FABS-110P: 6W

Mechanical	
Construction	304 Stainless steel front bezel (Default) 316L Stainless steel front bezel (Optional) Aluminum die-casting back cover
Mounting	Panel mount, VESA mount 100 x 100
IP Rating	IP66/IP69K compliant front bezel
Dimensions (WxHxD)	296 x 200 x 46.9 mm
Net Weight	2.4 kg

Dimensions

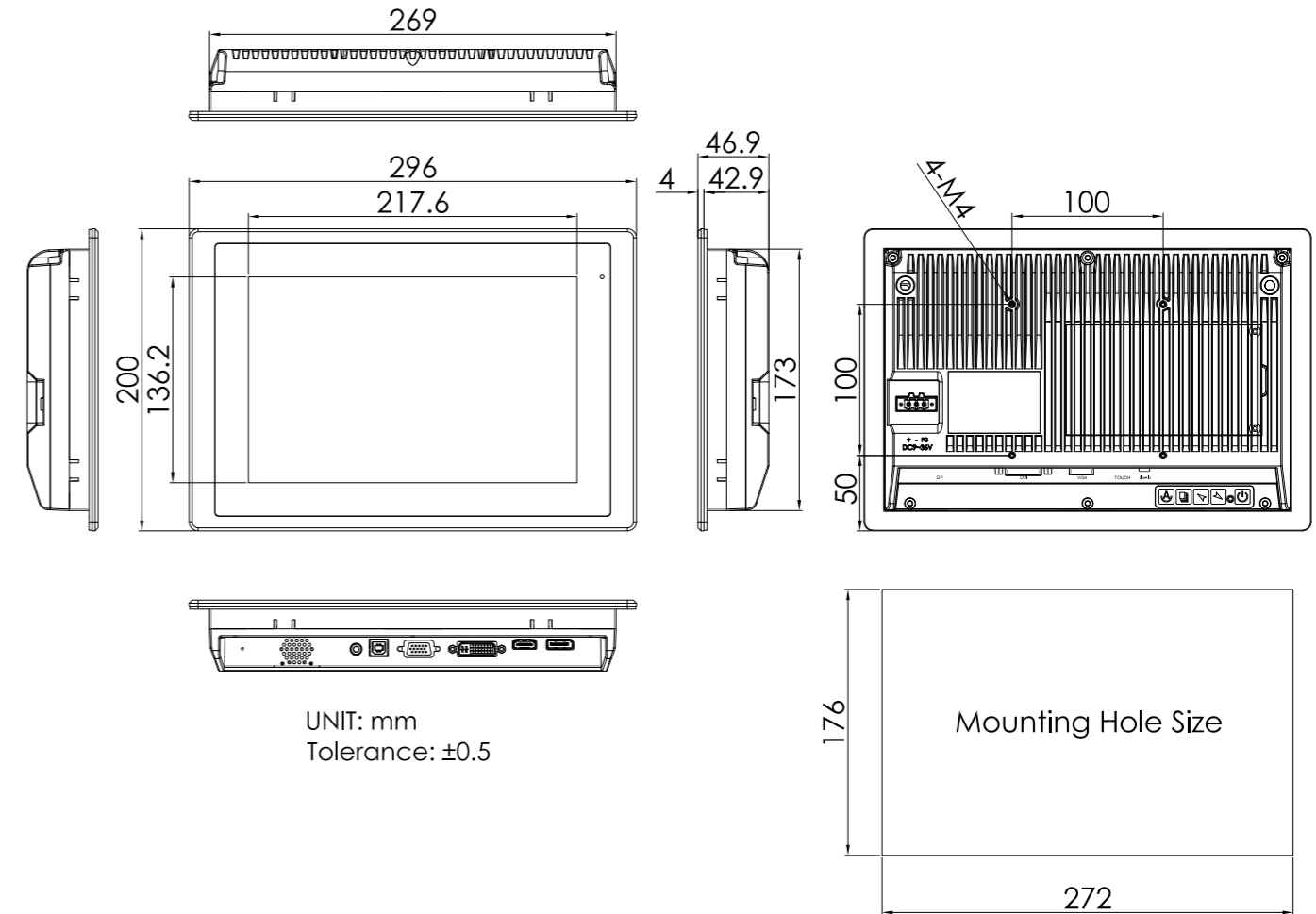

Environmental	
Operating Temperature	0~50°C / -20~60°C (option)
Storage Temperature	-30~70°C
Humidity	10 to 95% @ 40°C, Non-condensing
Certificate	R/P/G/RH/PH/GH Model: CE/FCC Class A P/G Model is compliance with EN 1672-2 (option)
Vibration	1G/5~500Hz (Random) / Operation
Shock	15G peak acceleration (11 msec. duration) / Operation

