

### Features

- 15" Industrial Compact Size Panel PC
- Intel Celeron N2930(1.83GHz) CPU built-in / Atom E3845(1.91GHz) for option
- Onboard 4GB DDR3L 1333MHz/ 8GB(option)
- Flat Front Panel Touch Screen and Fanless Design
- DC 9~36V Wide-Ranging Power Input
- IP66 Compliant Front Panel
- Optional Projected Capacitive Touch Screen Support 7H Anti-Scratch Surface
- High Brightness 1,000 nits for option

### Specifications

System		
CPU	Intel Celeron N2930 Processor (2M Cache,1.83GHz) Atom E3845 Processor (2M Cache,1.91GHz)	
System Chipset	SoC	
Memory	Onboard 4GB DDR3L SDRAM, up to 8GB (option)	
I/O Port		
USB	2 x USB 3.0 type A	
Serial / Parallel	1 x DB-9 RS-232/422/485, COM1 (Default RS-232) 1 x RS-232 DB-9, COM2	
Audio	1 x Audio Line Out	
LAN	2 x GbE LAN RJ-45	
Power	1 x 3-pin DC power input terminal 1 x 2-pin connector for power on/off button	
Option	VESA Stand 4G LTE/WIFI/ BT 4 x USB 2.0 type A (TB-528U4) 4 x USB 2.0 type A + 1 x Mini-PCIe + 1 x SIM slot (TB-528U4ME1) 2 x COM (RS-232) (TB-528C2) 1 x COM (RS-232) + 2 x USB 2.0 (TB-528C1U2) 1 x COM (RS-232) + 2 x USB 2.0 + 1 x Power Button (TB-528C1U2P1) 2 x COM (RS-232) + 1 x Mini-PCIe slot + 1 x SIM slot (TB-528C2ME1) 2 x COM (RS-422/485, isolated) (TB-528C2I) 2 x CAN (TB-528CAN2) 1 x LAN + 2 x USB 2.0 type A (TB-528E1U2) 1 x LAN(25W isolated PoE PD) + 2 x USB 2.0 type A (TB-528E1U2POE)* 1 x LAN(45W isolated PoE PD) + 2 x USB 2.0 type A (TB528E1U2UPOE) Backup Battery 21Wh/10.8V/1.95Ah(3S1P) System is only allowed to build in either TB-528 PoE series or backup battery	
Storage Space		
HDD	1 x 2.5" SATA3 HDD space	
Movable Device	1 x Micro SD card slot, up to 32GB	
Expansion		
Onboard Expansion bus	1 x Mini-PCIe slot (full size) 1 x Micro SIM slot	
Display		
	Standard	High Brightness Optional
Display Type	15" TFT-LCD	15" TFT-LCD
Max. Resolution	1024 x 768	1024 x 768
Max. Color	16.2M	16.7M
Luminance (cd/m <sup>2</sup> )	300	1000
View Angle	176(H) / 176(V)	176(H) / 176(V)
Contrast	1000:1	800:1
Backlight Lifetime	70,000 hrs	70,000 hrs
Touch Screen		
Type	Resistive Touch Projected Capacitive Touch (for P model)	
Interface	USB	
Light Transmission(%)	Resistive Touch: 80% Projected Capacitive Touch: 90%	

### Dimensions

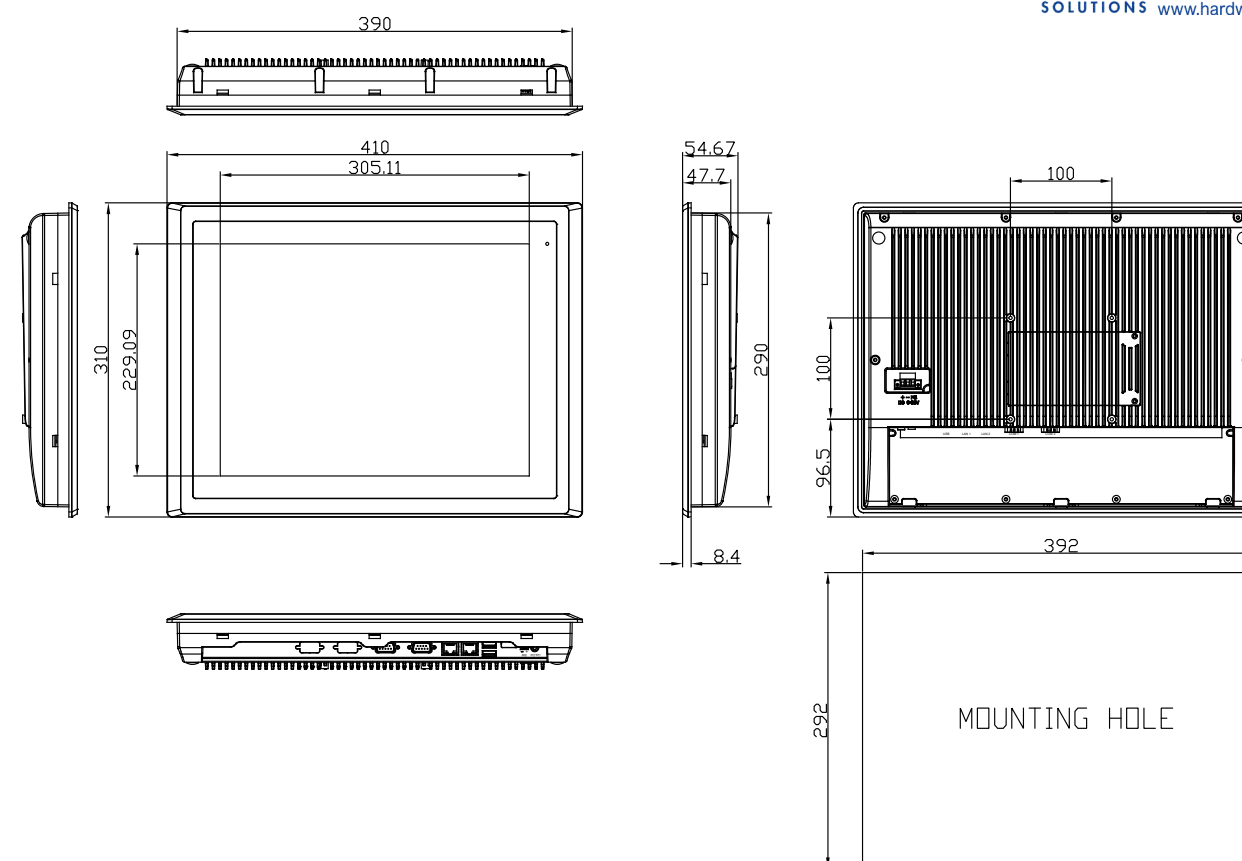

Power	
Power Input	DC 9~36V
Power Consumption	ARCHMI-815P: 30W (MAX)
Mechanical	
Construction	Aluminum Die-casting Chassis
Mounting	Panel Mount, VESA 100 x 100
Dimensions (WxHxD)	410 x 310 x 54.67 mm
IP Rating	IP66 Compliant Front Bezel
Net Weight	3.1 kg
Environmental	
Operating Temperature	0~50°C / -20~60°C (option)
Storage Temperature	-30~70°C
Humidity	10 to 90% @ 40°C, non-condensing
Certificate	CE/FCC Class A/CB/UL
Operating System Support	
Windows 10 IoT	
Ordering Information	
ARCHMI-815	15" XGA Fanless HMI barebone with Intel N2930 1.83G CPU, 2GB DDR3L RAM, Resistive touch screen, DC 9~36V input with adapter, Aluminum chassis
ARCHMI-815P	15" XGA Fanless HMI barebone with Intel N2930 1.83G CPU, 2GB DDR3L RAM, Projected Capacitive touch screen, DC 9~36V input with adapter, Aluminum chassis
ARCHMI-815H	15" XGA fanless HMI barebone with Celeron N2930(1.83.GHz ) CPU, 4GB DDR3L RAM, Resistive touch screen, DC 9~36V input with adapter, Aluminum chassis, 1,000 nits LCD
ARCHMI-815PH	15" XGA fanless HMI barebone with Celeron N2930(1.83.GHz ) CPU, 4GB DDR3L RAM, Projected Capacitive touch, DC 9~36V input with adapter, Aluminum chassis, 1,000 nits LCD

\*PoE limitation: CPU turbo off, rear I/O no loading, 70% LED backlight, PSE cable length < 50m